

## DALI TYPE 8 PROTOCOL

---

### 1.1 DALI Type 8 Protocol Specifications

Digital Addressable Lighting Interface (DALI) is a communication language. DALI facilitates the communication and therefore control of multiple devices such as drivers, transformers and other lighting equipment. Devices which speak the same language can exchange information, in much the same way people can exchange information when they communicate using the same language.

#### DALI Devices:

Designed on a distributed intelligent framework, each DALI device has on-board memory that stores all relevant information about the device, including diagnostics, which reduces the technical requirements on the control system and the amount of data to be transmitted over the line.

#### DALI Standards:

- DALI is a lighting control standard defined under the European Standard IEC 62386 .
- IEC stands for International Electrotechnical Commission and is a non-profit organization.
- DALI was designed to replace traditional 1-10 V analog systems and proprietary digital systems such as DSI (Digital Serial Interface).
- At a maximum there can be 64 DALI devices on a single DALI line and it has a data baud rate of 1200 baud.

#### DALI Technical Specifications:

Numbers of units: max. 64

Numbers of addresses: 64

Signal level: +/- 16V

Cable length: max. 300m, and less than 2V voltage drop

Cable type: any 2 wire unshielded cable

Cable topology: any (line, star, tree, ring)

Refresh rate: max 40 messages / second +/- 1200 baud Safety

DALI is not SELV; cable must be treated like mains wiring

Maximum DALI-compliant Bus Wire Length:

1.5 mm<sup>2</sup> (300 m)

0.75 mm<sup>2</sup> (150 m)

0.50 mm<sup>2</sup> (100 m)

A DALI system contains one current source, a controller and input(s). In idle state the current signal is “high” so there is current. A driver input current is 2mA in idle state. Nominal current for 64 inputs is 128mA. Information is transferred by short circuiting the current, (controller / input). Communication is always started by the controller. An input can only “answer” (= back channel info). Random addressing is possible. DALI units have no address from factory. Any address can be changed via the DALI connection. An input can detect if the DALI current is present.

## DALI TYPE 8 PROTOCOL

---

### 1.2 DALI Type 8 Wiring Specifications

DALI Wiring can be run up to 300m using 1.5mm cable. (15 awg) The DALI specification allows for maximum 2V drop in the communication signal. The DALI line does not require termination of the line and supports all wiring typologies except rings and closed loops (trees, branches and chains are all acceptable).

The following are National Electric Code (NEC 70) requirements.

#### DALI Class 1 and Class 2 Wiring Overview:

DALI dimming ballasts and drivers are connected together by a 2-wire low voltage bus that is suitable for Class 1 or Class 2 wiring installations. This application note explains how both Class 1 and 2 wiring are made and how they both meet National Electric Code (NEC) regulations.

#### DALI Dimming Ballast and Driver Wired Class 2:

For more information on Class 2 wiring and additional Class 2 wiring requirements see National Electric Code Article 725. With regards to factory installed wiring, as per UL1598 section 6.17.1: Factory-installed power limited wiring and branch circuit wiring that come in random contact within the luminaire shall have insulation rated for the maximum voltage that exists in any of the circuits.

If wiring with the properly rated insulation is used, then no spacing or separation is required regardless of the circuit conductor voltage although shielding may be required.

Class 2 wiring of the DALI dimming ballast and driver follows the NEC Requirement 725.136(D) (references to Class 3 are eliminated).

Class 2 circuit conductors in compartments, enclosures, device boxes, outlet boxes, or similar fittings shall be permitted to be installed with electric light, power, Class 1 circuits where they are introduced solely to connect the equipment connected to Class 2 circuits and where (1) or (2) applies:

1. The electric light, power, Class 1 circuit conductors are routed to maintain a minimum of 6 mm (.25 in) separation from the conductors and cables of Class 2.
2. The circuit conductors operate at 150 volts or less to ground and also comply with one of the following:
  - A. The Class 2 circuits are installed using Type CL3, CL3R, or CL3P or permitted substitute cables provided these Class 3 cable conductors extending beyond the jacket are separated by a minimum of 6 mm (0.25 in) or by a nonconductive sleeve or nonconductive barrier from all other conductors.
  - B. The Class 2 circuit conductors are installed as a Class 1 circuit.

The DALI dimming ballast and driver have a minimum spacing of 0.25 inches between line voltage and the bus terminals (purple and grey wires) for Class 2 installations.

#### DALI Bus Wired Class 1:

Class 1 wiring methods follow the NEC Requirement 725.48.

Class 1 circuits shall be permitted to be installed with other circuits as specified in 725.48 (A) and (B):

- A. Class 1 circuits shall be permitted to occupy the same cable, cable tray, enclosure, or raceway without regard to whether the individual circuits are alternating or direct current, provided all conductors are insulated for the maximum voltage of any conductors in the cable, cable tray, enclosure or raceway.
- B. Class 1 circuits shall be permitted to be installed with power supply conductors as specified:
  1. Class 1 and power supply circuits shall be permitted to occupy the same cable, enclosure, or raceway only when functionally associated.

Since the DALI dimming ballast and driver meets Class 2 installation requirements, it can also be installed in a Class 1 configuration when Class 2 markings are not present. The NEC allows the reclassification of Class 2 circuits per Article 725.130 Exception No.2:

Class 2 and circuits shall be permitted to be reclassified and installed as Class 1 circuits if the Class 2 markings are eliminated and the entire circuit is installed using the wiring methods and materials in accordance with Part II, Class 1 circuits.

Note: For more information regarding Class 2 wiring and additional requirements see the National Electrical Code Article 725.

#### Reference Information:

Code quotation, guidance, and wiring guides above are listed for reference only. Always follow local and national wiring requirements. NEC 2008 was used as a reference in this Application Note. More recent releases of the National Electrical Code should always be consulted. The National Electrical Code (NEC) is a registered trademark of the National Fire Protection Association, Quincy, MA.

## DALI TYPE 8 WIRING DIAGRAMS

### 2.1a DALI Type 8 Accessory Card Wiring Diagram araya Logic Module (ALM3) with Linear Arrays (LTM3)

**Notes:**

1. Power (red/black) is Class-2 rated.
2. One DALI address per linear array/ALM3 kit.

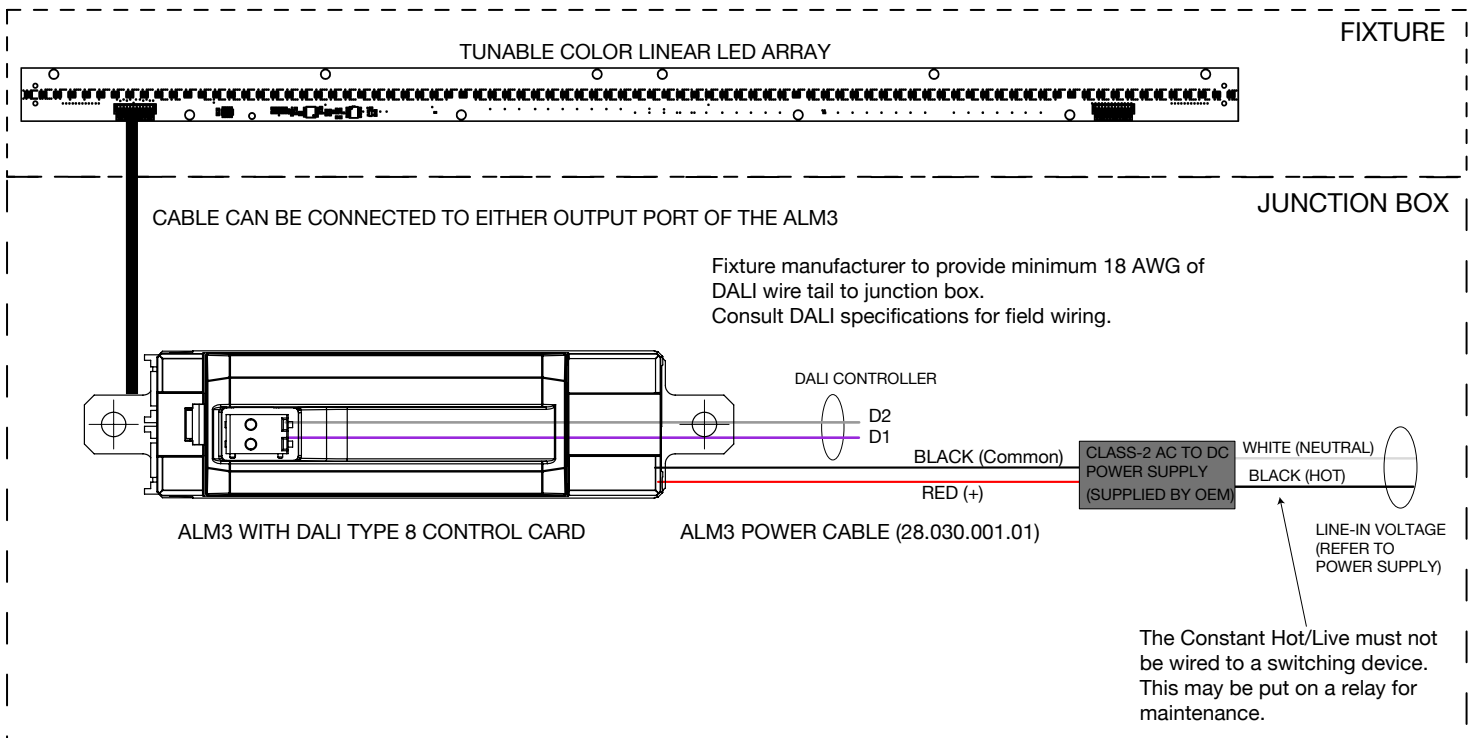

## DALI TYPE 8 WIRING DIAGRAMS

### 2.1b DALI Type 8 Accessory Card Wiring Diagram araya Logic Module (ALM3) with Round Arrays (CTM3)

**Notes:**

1. Power (red/black) is Class-2 rated.
2. One DALI address per round array/ALM3 kit.

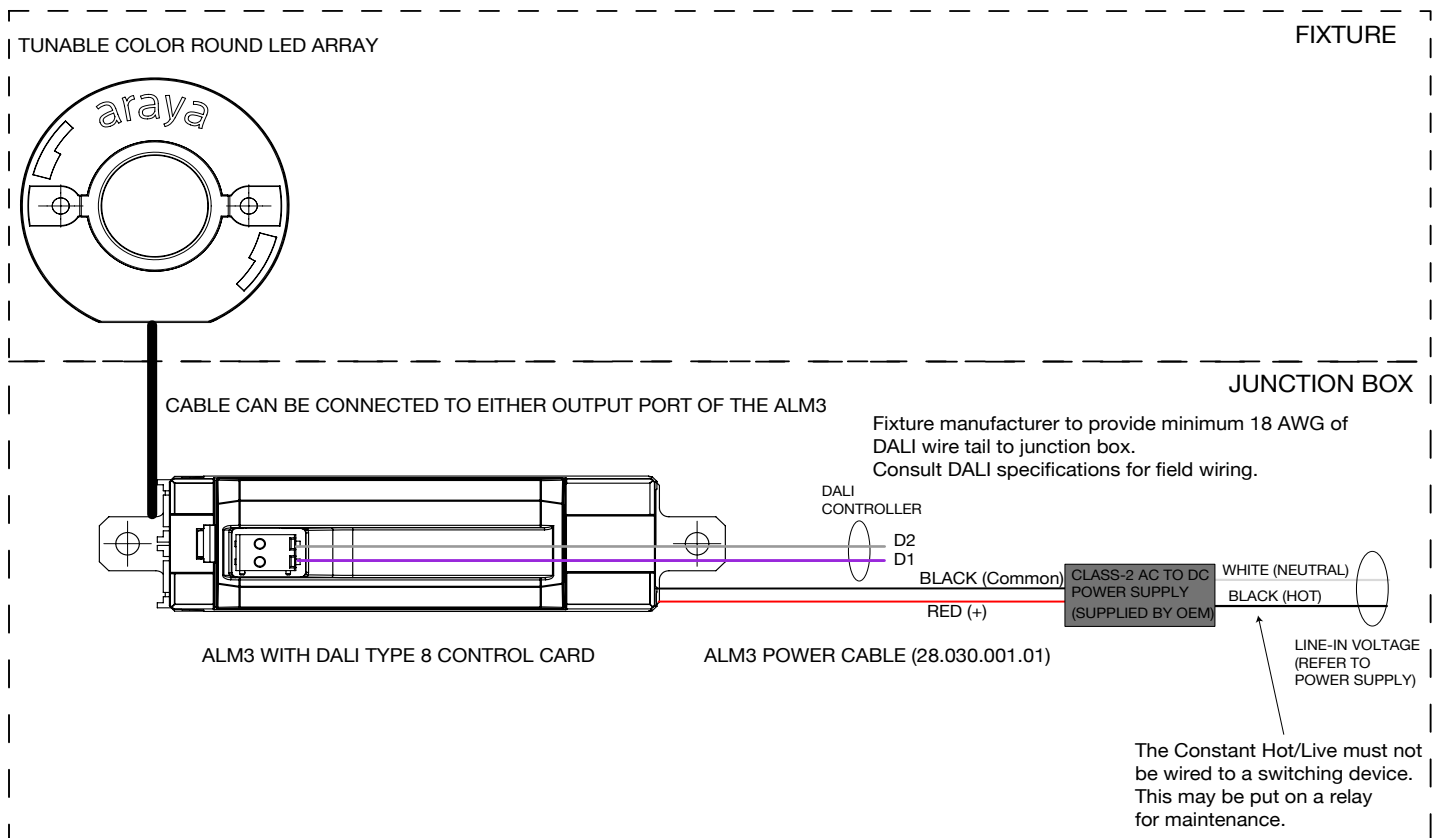

## DALI TYPE 8 WIRING DIAGRAMS

### 2.2a DALI Type 8 Accessory Card Wiring Diagram araya Logic Module (ALM2) with Linear Arrays (LTM2)

**Notes:**

1. 24 V power (red/black) is Class-2 rated.
2. One DALI address per linear array / ALM kit.

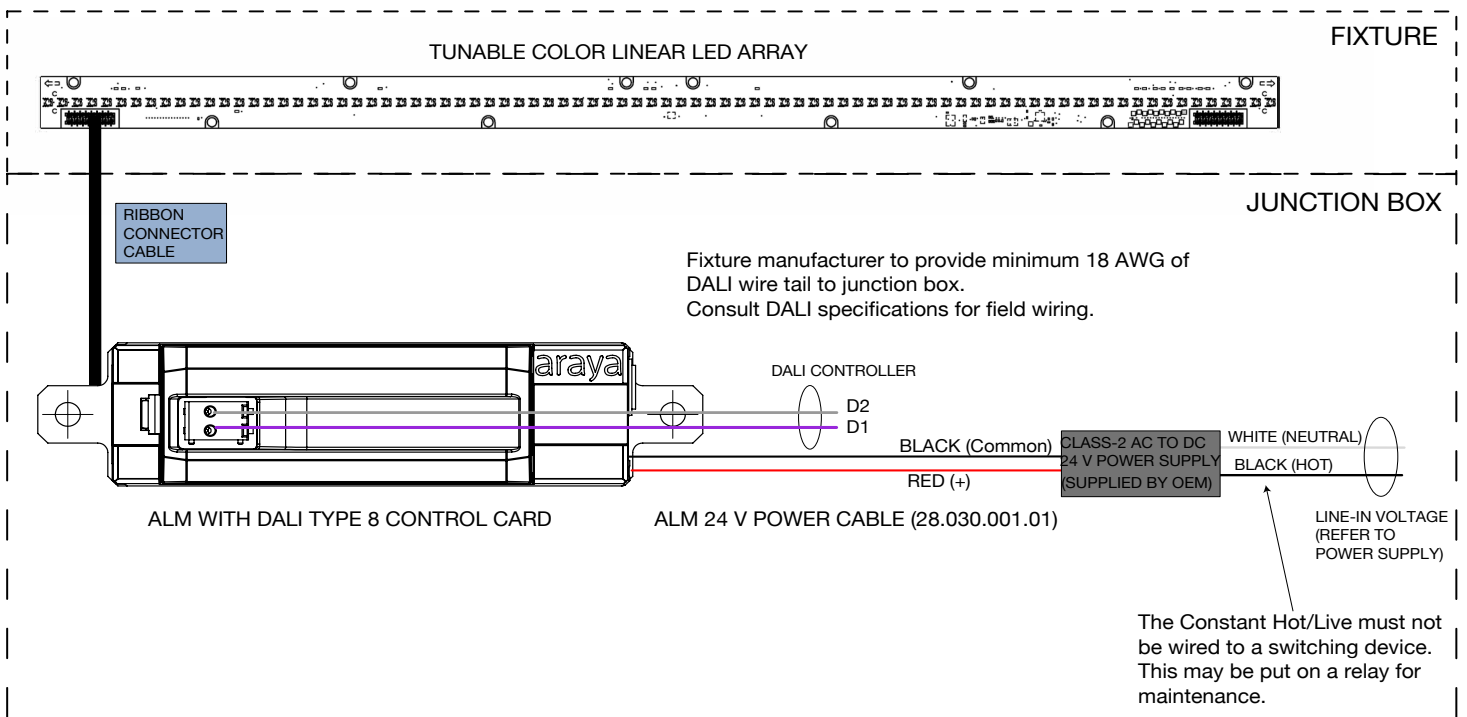

## DALI TYPE 8 WIRING DIAGRAMS

### 2.2b DALI Type 8 Accessory Card Wiring Diagram araya Logic Module (ALM2) with Round Arrays (CTM2)

**Notes:**

1. 24 V power (red/black) is Class-2 rated.
2. One DALI address per linear array / ALM kit.

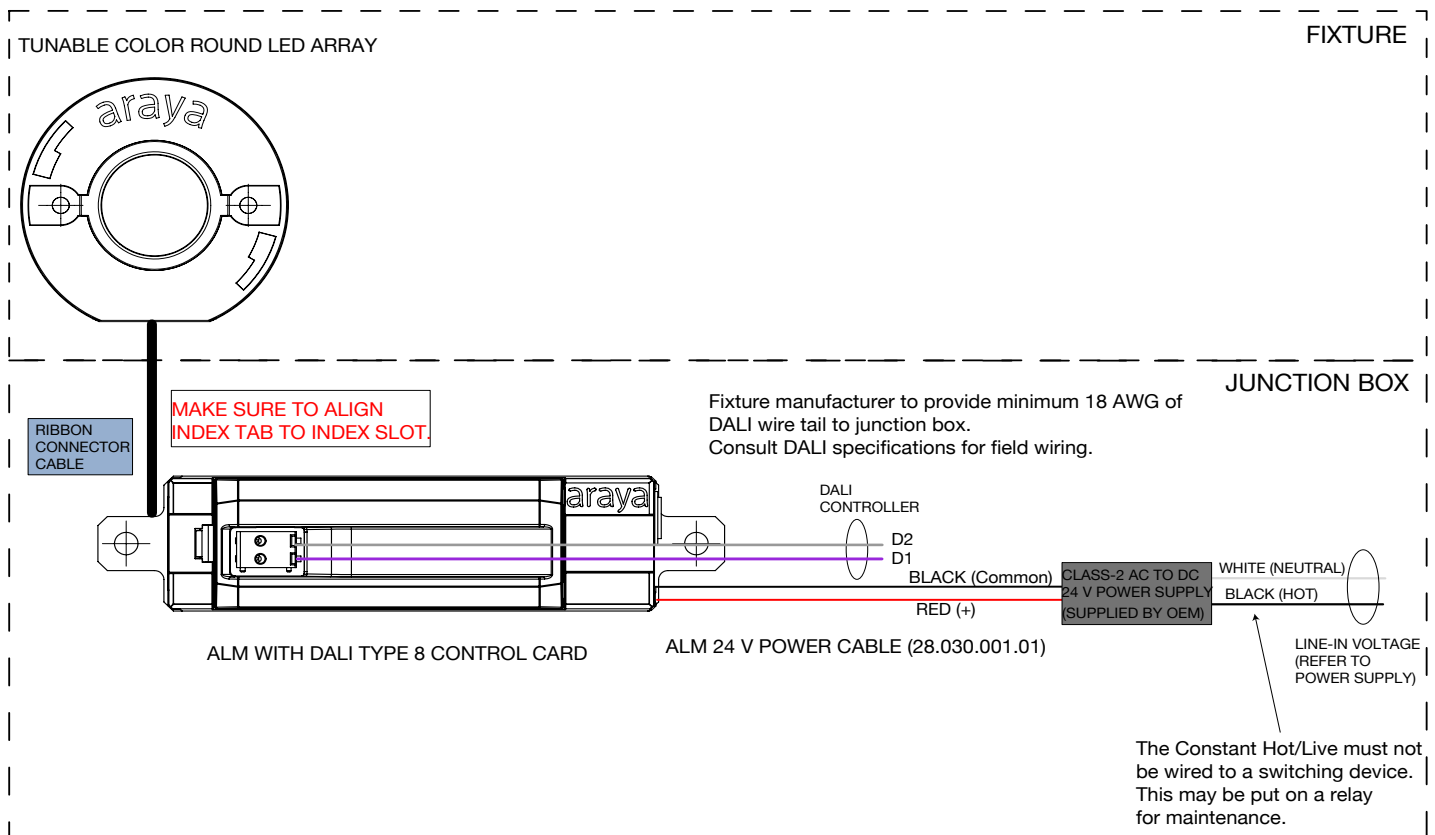

**IMPORTANT:**

CTM 241 IS PROVIDED WITH TWO ALMS AND REQUIRES TWO POWER CABLE ASSEMBLIES, TWO CONTROL CABLE ASSEMBLIES, AND TWO RIBBON CABLES FOR FULL FUNCTIONALITY AND PERFORMANCE. THE WIRING CONNECTIONS AND THE ALM WILL BE MIRRORED ON **TWO** CONNECTOR OPENINGS (LABELED AS LEFT AND RIGHT) ON THE MODULE. THE ALM LABELED "LEFT" AT ONE END SHOULD ONLY BE ATTACHED VIA RIBBON CABLE TO THE CONNECTOR OPENING LABELED "LEFT". THE OTHER ALM LABELED "RIGHT" AT ONE END SHOULD ONLY BE ATTACHED VIA RIBBON CABLE TO THE CONNECTOR OPENING LABELED "RIGHT".

## DALI TYPE 8 WIRING DIAGRAMS

### 2.3a DALI Type 8 Input; Digital Control Adapter (DCA) DDM1C (one channel) / CTM1C (two channel) – 24 V

**Notes:**

1. 24 V power (red/black) is Class-2 rated.
2. Module Data +/- (white with orange stripe/orange) to Lumenetix-araya modules is Class-2 rated. The Tunable Color 2.0 iOS App should be turned on, and the DMX channels should be set to 2, 4, 6, 8.
3. Adapter is configured at factory for DALI inputs.
4. DCA may be installed in the luminaire only.
5. One DALI address per CTM or DDM module / DCA kit.
6. CAUTION: The power cable should ONLY be plugged into the 2-pin power receptacle provided. Insertion of the cable into any other slot will damage the Digital Control Adapter unit.
7. DMX Output used with this system.

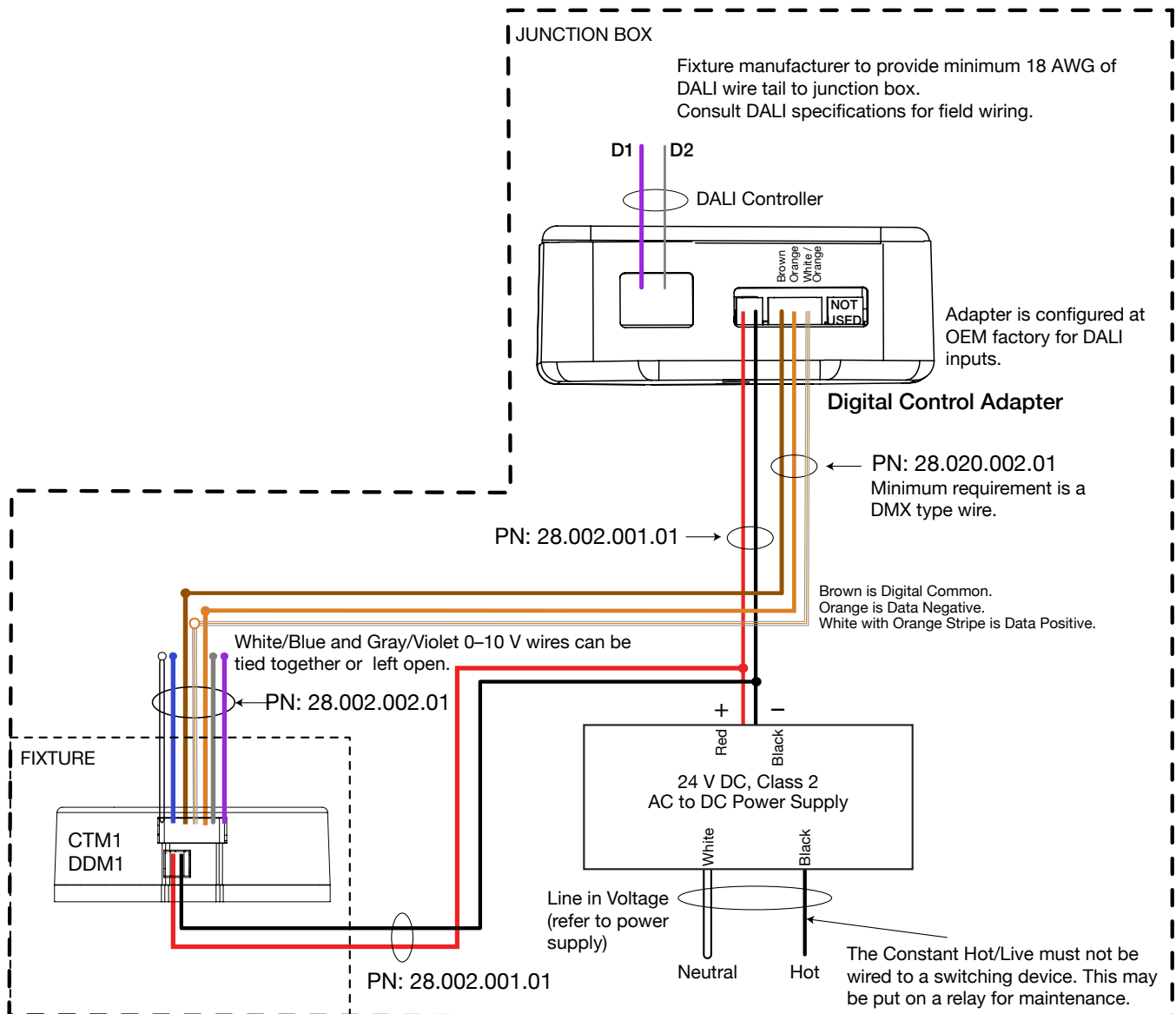

## DALI TYPE 8 WIRING DIAGRAMS

### 2.3b DALI Type 8 Input; Digital Control Adapter (DCA) DDM1C (one channel) / CTM1C (two channel) – 12 V

**Notes:**

1. 12 V power (red/black) is Class-2 rated.
2. Module Data +/- (white with orange stripe/orange) to Lumenetix-araya modules is Class-2 rated. The Tunable Color 2.0 iOS App should be turned on, and the DMX channels should be set to 2, 4, 6, 8.
3. Adapter is configured at factory for DALI inputs.
4. DCA may be installed in the luminaire only.
5. One DALI address per CTM or DDM module / DCA kit.
6. CAUTION: The power cable should ONLY be plugged into the 2-pin power receptacle provided. Insertion of the cable into any other slot will damage the Digital Control Adapter unit.
7. DMX Output used with this system.

